

Installation Manual

**C-2410
ARNOTT REAR
COIL SPRING CONVERSION KIT
FOR 2003-2009
LEXUS GX-470/
TOYOTA 4RUNNER/TOYOTA PRADO**

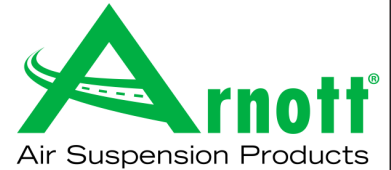

Congratulations on your purchase of an Arnett® air suspension product. We at Arnett Incorporated are proud to offer a high quality product at the industry's most competitive pricing. Thank you for your confidence in us and our product.

Proper installation is essential to experience and appreciate the benefits of this system. Please take a moment to review these installation instructions before you begin to install these components on your vehicle. The removal and installation of air suspension products should only be performed by a fully qualified, ASE Certified, professional.

It is equally important to be aware of all necessary safety measures while installing your new Air Suspension System. This includes proper lifting and immobilizing of the vehicle and isolation of any stored energy to prevent personal injury or property damage.

"Engineered to Ride, Built to Last®"



WARNING: *The air suspension system is under pressure (up to 10 bar, or 150 lbf/in). Verify pressure has been relieved and disconnect power to the air suspension system prior to disassembly. Do not allow dirt or grease to enter the system. Always wear standard hand, ear, and eye protection when servicing the air suspension system.*

Arnett® is committed to the quality of its products. If you have a question or problem with any Arnett product, please contact Arnett by calling **800-251-8993** during normal business hours or email techassistance@arnottinc.com.

GENERAL INFORMATION:

Reading this manual signifies your agreement to the terms of the general release, waiver of liability, and hold harmless agreement, the full text of which is available at www.arnottinc.com.

- Not to be stored below 5°F (-15°C) or above 122°F (50°C).
- Avoid damage to air lines and cables.
- Removal and installation is only to be performed by fully qualified personnel.
- Use car manufacturer's diagnostic software.

CAUTION: *Damage to the vehicle and air suspension system can be incurred if work is carried out in a manner other than specified in the instructions or in a different sequence.*



To avoid the possibility of short circuits while working with electric components consult your owner's manual on how to disconnect your battery.



Consult your vehicle owner's manual, service manual, or car dealer for the correct jacking points on your vehicle and for additional care, safety and maintenance instructions. Under no circumstances should any work be completed underneath the vehicle if it is not adequately supported, as serious injuries and death can occur.

REAR AIR SPRING REMOVAL

1. Set the steering to straight ahead.
2. Raise the vehicle.
3. Remove the rear wheels.
4. Deflate both rear air springs by disconnecting the air lines leading from the valve block assembly to the rear air spring.
5. Remove the locking clip from the top side of the rear air spring.
6. Disconnect the air line from the air spring.
7. Carefully remove air spring from the vehicle.
8. Seal off hose to prevent dirt or grease from entering system.
9. Remove both lower shock bolts. Allow axle to hang free unsupported. This will give you extra clearance for the coil spring.

COIL SPRING INSTALLATION



Tighten all nuts and bolts to manufacturer's specifications during the installation process.

NOTE:

Tie the wires and air hose back away from any hot or moving parts. Do not cut the wires. Leave the system whole in case you ever want to reinstall air suspension on the vehicle.

1. Install the upper spring isolator on top of the coil spring.
2. Install the rear springs onto the rear axle.
3. Using a floor jack, raise the rear axle.
4. Install the lower shock absorber retaining nut and bolt to the rear axle.
5. Remove the rear axle support.
6. Replace tire and wheel assembly.
7. Remove all safety stands and lower vehicle.
8. Installation complete.

DISARMING THE AIR SUSPENSION SYSTEM

1. Remove the fuse from the air suspension compressor. The 50 amp fuse is located in the fuse box under the hood. This will deactivate the air suspension system. The "off" light located next to the height control lamp will continue to blink. You will still be able to use the suspension damping adjustment control to firm up the suspension shocks.

REMOVAL DIAGRAM

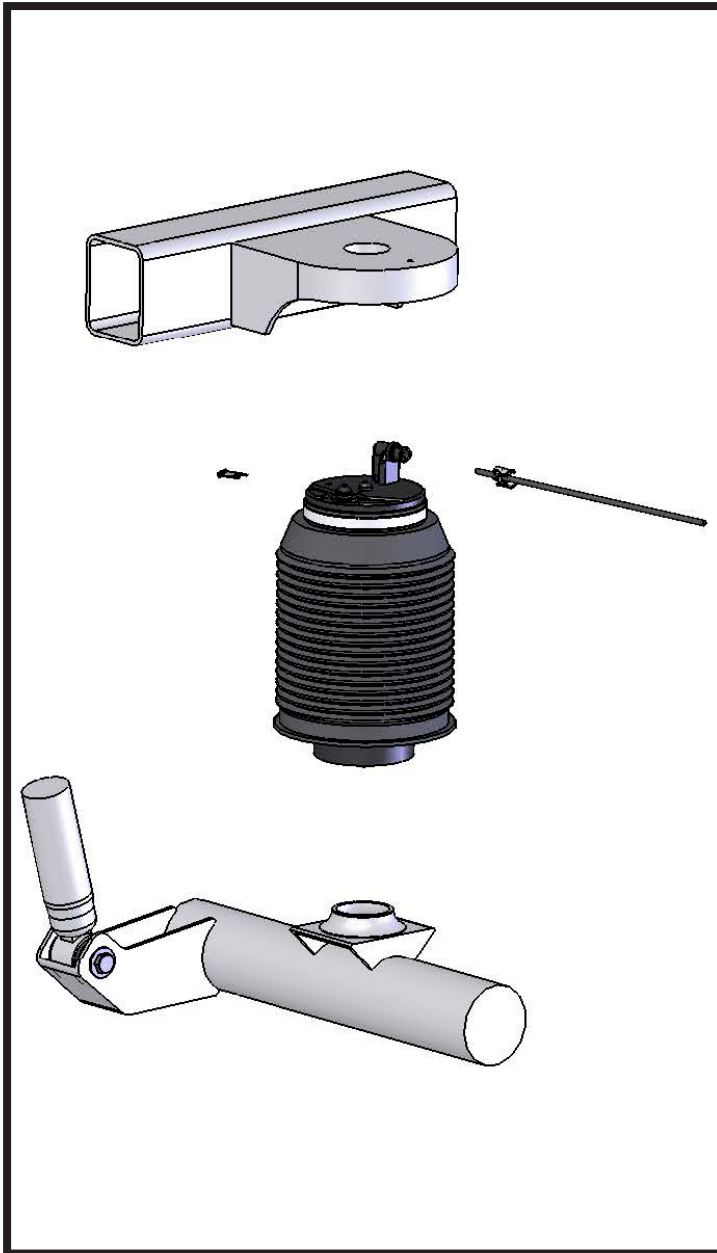

INSTALLATION DIAGRAM

